



SMOOTH PEOPLE FLOW[®] FOR TRANSIT CENTERS

KONE TransitMaster™ 120

YOUR TRUSTED ESCALATOR PARTNER

With over 100 years of experience and a strong track record in safety, KONE is your trusted partner, dedicated to ensuring smooth and safe People Flow™ in today's highly demanding public environments. KONE's reliable escalator and autowalk solutions use proven technology and highly durable components designed to meet the heavy usage demands to infrastructure environments worldwide.

The KONE TransitMaster™ 120 escalator is designed specifically to meet the needs of environments with medium to high traffic flow and round-the-clock operation. These include railway and metro stations, as well as airports and other mass transit centers, where high reliability and long equipment lifetime are key requirements.

3 REASONS TO CHOOSE KONE TRANSITMASTER 120™

1 EXCELLENT ECO-EFFICIENCY THAT REDUCES OPERATIONAL COSTS

- The KONE Direct Drive is up to 20% more energy efficient than conventional drive solutions
- Smart operational modes and an all new inverter optimize energy consumption under different load conditions



The KONE TransitMaster™ 120

- Vertical rise: Up to 15 meters
- Horizontal steps: 2, 3 or 4
- Inclination: 27.3°, 30°, 35°
- Step width: 800 mm, 1000 mm
- Radius: 1.0/1.0, 1.5/1.0, 2.7/2.0
- Balustrade height: 900 mm, 1000 mm, 1100 mm
- Speed: 0.4 m/s with inverter, 0.5 m/s, 0.65 m/s, 0.75 m/s
- Step chain: Inside roller chains
- Operational environment: Indoor, semi-outdoor, full outdoor
- Duty cycle: 20 hours/day

2 PEACE OF MIND WITH THE LATEST SAFETY TECHNOLOGY

- New traffic signalization solutions
- Audible alarms provide clear guidance on escalator travel direction

3 HIGH QUALITY, DURABLE DESIGN FOR THE BEST POSSIBLE USER EXPERIENCE

- Innovative and attractive lighting solutions that also improve passenger guidance and safety.
- A wide range of design options to create stunning visual effects and perfectly match your building's architecture.
- High quality, durable component finishes designed to withstand heavy traffic flow, and a harmonized look and feel throughout the KONE product portfolio.

ECO-EFFICIENT ESCALATOR

At KONE we have always been renowned for our revolutionary, reliable, and eco-efficient technology. The KONE TransitMaster 120™ is powered by KONE Direct Drive, which is up to 20% more efficient than conventional worm-gear drive solutions. Installing an eco-efficient KONE escalator solution can also help achieve green building accreditations such as LEED or BREEAM certification.

POWER IN OPERATION – KONE DIRECT DRIVE VS. WORM GEAR

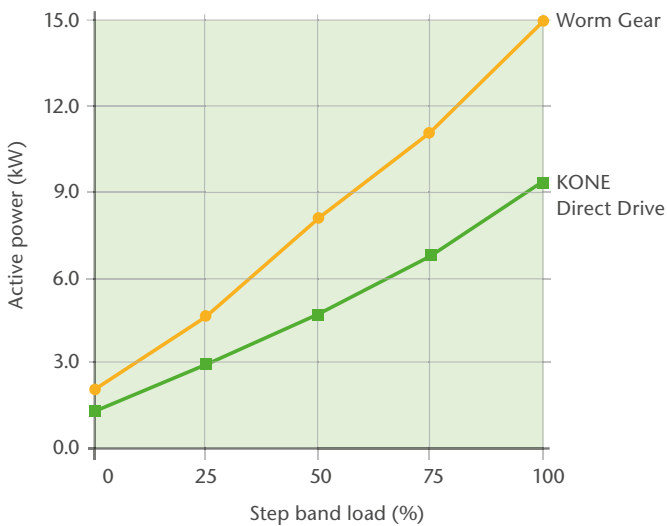

Energy measurements made at a Helsinki Metro station on November 23rd, 2011.

Forbes | 2015
THE WORLD'S MOST INNOVATIVE COMPANIES
Powered by The Innovators DNA

U.S. based business magazine Forbes has ranked KONE the 48th most innovative company in the world. KONE is also the only construction service company that has made it to the top 50.

- ### 1 A MORE EFFICIENT DRIVE

The KONE-designed Direct Drive helps cut operating costs. By replacing the conventional worm gear drive with the KONE Direct Drive, mechanical losses have been minimized, reducing the drive's energy consumption by up to 20%*.
- ### 2 ALL-NEW ENERGY EFFICIENT INVERTER

The renewed inverter ensures smooth speed regulation during standby operation and minimizes energy consumption at full speed. This means even better escalator energy efficiency in transit centers with fluctuating traffic peaks.
- ### 3 ECO-EFFICIENT OPERATIONAL MODES

Eco-efficient operational modes save energy by slowing down or stopping the escalator completely when traffic is low. For example, when an escalator is empty, energy consumption is further reduced with KONE's smart star-delta operational mode, which regulates the current needed for different types of load situations.
- ### 4 LONG-LASTING LED LIGHTING

LED lighting is up to 80% more efficient than fluorescent lighting and lasts up to 10 times longer.

* Based on a study conducted in US in 2011 by KONE R&D for drive gears efficiency.

KONE DIRECT DRIVE

The KONE Direct Drive is the eco-efficient heart of the KONE TransitMaster 120™ escalator. As well as delivering excellent energy efficiency under variable traffic conditions, this innovative, reliable technology also improves passenger safety and makes maintenance safer and easier than ever before.

1 SMART, EFFICIENT POWER WITH RELIABLE PERFORMANCE

- **Eco-efficient design**, with the motor directly connected to the main shaft by the gear, and low input power requirements.
- **Extra power for demanding people flow**, with the possibility to combine two drives to power the escalator step chain in heavy-traffic environments.

2 SIMPLER MAINTENANCE, MINIMIZES DOWNTIME, AND LONGER EQUIPMENT LIFETIME

- **Minimized downtime and efficient maintenance** thanks to the drive being located outside the step band, which means easier, faster access for service technicians and minimal downtime.
- **Fewer spare parts needed** because of the drive's simple configuration and chainless design.
- **No risk of oil on the step band** due to the external location of the drive, which eliminates the possibility of lubrication oil dripping onto the steps.

3 INCREASED SAFETY

- **Chainless design** eliminates the risk of chain failure, further boosting reliability.
- **External drive location** means maintenance is safe and efficient, as there is no need to remove any steps.

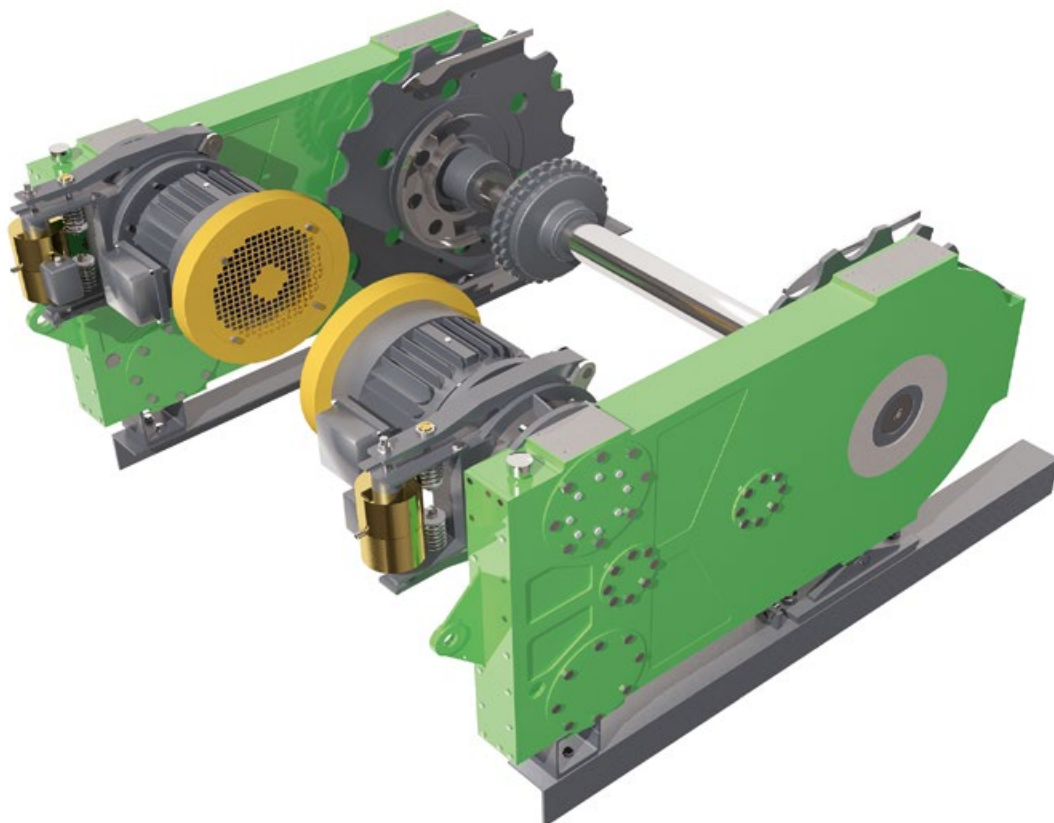

PEACE OF MIND

WITH THE LATEST SAFETY TECHNOLOGY

When you choose KONE, you choose peace of mind. Safety is the starting point for every KONE solution. All our escalators are designed to meet and exceed all applicable safety standards, codes, and regulations to ensure the highest levels of safety every step of the way – from planning and installation to maintenance and modernization. In addition, we offer new and innovative features to ensure that KONE escalators are the benchmark whenever safety is concerned.

The KONE TransitMaster™ 120 has been designed to both maximize safety for passengers and make it easy to inspect the condition of the equipment, ensuring that it operates reliably and safely at all times, even under the most demanding traffic conditions.

Standards-compliant manufacturing

All KONE manufacturing units are ISO 14001 certified and meet all relevant escalator industry standards and requirements. KONE escalators comply with international codes such as EN115, as well as local codes that incorporate additional requirements for escalator safety.





COMPREHENSIVE RANGE OF SAFETY OPTIONS

1 KONE DIRECT DRIVE

The KONE Direct Drive's chainless design eliminates the risk of chain failure, while the drive is located outside the step band for efficient and safe maintenance, and minimized downtime.

2 ALARM FOR TRAVEL DIRECTION

An alarm sounds if passengers enter an escalator in the wrong direction.

3 VISUAL GUIDANCE

Traffic signalization, skirt lighting, yellow comb segment, and step demarcations provide extra visual guidance for passengers.

4 FALL-PREVENTION FEATURES

A fall-protection barrier and extended balustrades provide additional passenger protection.

For a complete list of standard and optional safety features please contact your local KONE sales representative.

HIGH QUALITY, DURABLE DESIGN

FOR THE BEST POSSIBLE USER EXPERIENCE

As well as being a key transportation method for infrastructure environments, escalators are an important part of a building's ambience and style, and can be an important source of lighting too. Well-planned design can make an escalator more than just a people flow solution by turning it into an eye-catching architectural element that provides a more pleasant experience for travellers.

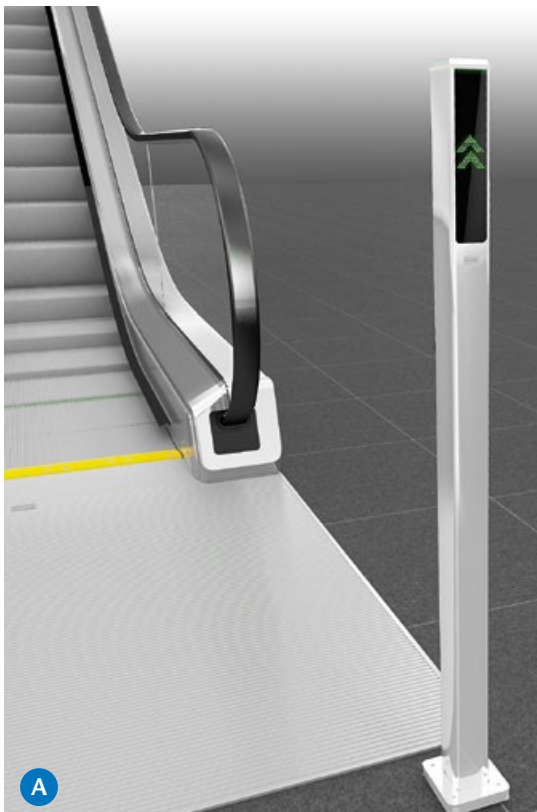

1 INNOVATIVE AND PRACTICAL LIGHTING SOLUTIONS

KONE's new cladding, lighting solutions for signs and traffic lights provide the final touch to your escalator's visual design. Our traffic-light options – cube, road sign, and traffic pole – provide a simple, stylish approach to safety and passenger guidance, ensuring smooth people flow even during heavy traffic peaks.

2 ATTENTION TO DETAIL AND DURABLE COMPONENTS

All of our escalator components are designed with great attention to detail. KONE escalators are equipped with attractive front plates, guards, and access covers – all with high quality, durable finishing. The design of KONE products is harmonized throughout our portfolio for a consistent look and feel in your building.

3 A WIDE RANGE OF DESIGN OPTIONS

KONE's design offering consists of a wide range of innovative materials and features. The combination of unique textured and patterned cladding materials with novel lighting solutions creates a stunning visual effect and contributes to a more pleasant experience for travellers.

4 TAILOR-MADE POSSIBILITIES

KONE's renowned engineering and design capabilities are always available to help you realize your architectural vision with customized specifications for your premises.

New attractive guidance solutions that improve the safety of your escalator: ◆

- A. Traffic light pole
- B. Traffic light cube
- C. Balustrade light
- D. Traffic light road sign





IDENTIFYING THE RIGHT ESCALATOR CONFIGURATION FOR YOUR PEOPLE FLOW™ NEEDS

People flow varies immensely in each type of building. Understanding the people flow needs and requirements of your building will help you select the correct escalator configuration.

Escalators used for public transportation purposes need to meet the high usage demands typically linked with airports as well as metro and train stations. Each escalator is a complex combination of components and technical characteristics. Many of these characteristics – vertical rise, speed, step width, inclination, etc. – are available in various specifications. To ensure the reliability and availability of escalators over their lifetime, it is essential that

each escalator’s specification matches the people flow conditions and requirements of the building where they will be located.

In order to make the selection of equipment easier, we have standardized many of these characteristics into truss packages which meet the different people flow requirements for public transportation environments.

STEP/PALLET WIDTH	NOMINAL SPEED		
	mm	0.50 m/s	0.65 m/s
600	3,600 persons/h	4,400 persons / h	4,900 persons / h
800	4,800 persons / h	5,900 persons / h	6,600 persons / h
1000	6,000 persons / h	7,300 persons / h	8,200 persons / h

Theoretical escalator movement capacity according to EN 115.

KONE SOLUTIONS FOR PUBLIC TRANSPORTATION		
0.5 m/s	0.65 m/s	0.75 m/s
30° inclination with 1.0/1.0 radius 35° inclination with 1.0/1.0 radius		
30° inclination with 1.5/1.0 radius		
30° inclination with 2.7/2.0 radius 27.3° inclination with 2.7/2.0 radius		



For additional information on how to calculate traffic capacity for escalators as well as a detailed look at how to plan the escalators in your building, take a look at KONE’s escalator and autowalk planning guide.

SUPPORTING YOU EVERY STEP OF THE WAY

Choose a partner with over a century of experience in delivering pioneering escalator solutions for demanding infrastructure environments around the world. Get expert advice from professionals and enjoy the peace of mind that comes with comprehensive support. KONE is with you every step of the way – from planning and design, through installation and maintenance, to modernization – for the entire life cycle of your building.

1 EXPERT DESIGN AND PLANNING SERVICES

- Expert planning advice helps you specify the optimal solution for your building.
- Easy-to-use online design tools save you time and effort during the design process by allowing you to create CAD drawings and 3D BIM models.
- Energy consumption calculations available for every individual escalator solution.

2 SAFE AND EFFICIENT INSTALLATION

- Highly efficient installation methods result in considerable cost savings for our customers and minimize disruption to other construction work.
- Strict quality criteria for each phase of installation ensure that it's right the first time, every time.
- Continuous training, site audits, safety passports, and proven methods ensure maximum site safety.
- Eco-efficient installation processes maximize waste recycling.

3 QUALITY ASSURANCE AND PROFESSIONAL MAINTENANCE

- KONE's own reliability laboratory tests and approves every component used in our escalator solutions, ensuring maximum reliability.
- Our global spares center stocks over 150,000 parts and offers 24-hour delivery for the most commonly requested parts, helping you minimize downtime by ensuring repairs can be carried out as quickly as possible.
- Preventive KONE Care® maintenance solutions – including a comprehensive new online service-reporting system – make it easier to monitor and budget for escalator maintenance.

WORLD-CLASS DESIGN TOOLS

KONE Escalator Toolbox – including BIM models

- With the KONE Escalator Toolbox you can create a detailed equipment specification online and customized CAD drawings for preliminary planning.

- KONE Building Information Modeling (BIM) models make it easier and quicker for architects to prepare digital escalator designs. Included in the Escalator Toolbox, these models are compatible with most common project documentation systems and include the latest KONE escalator specifications. Once your design is ready, you can send the specifications directly to a KONE sales representative for tendering and/or ordering.

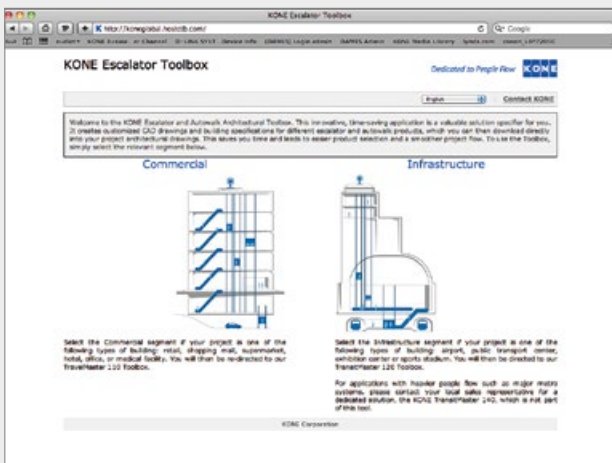

The KONE Escalator Toolbox is available online at <http://koneglobal.hostctb.com/>

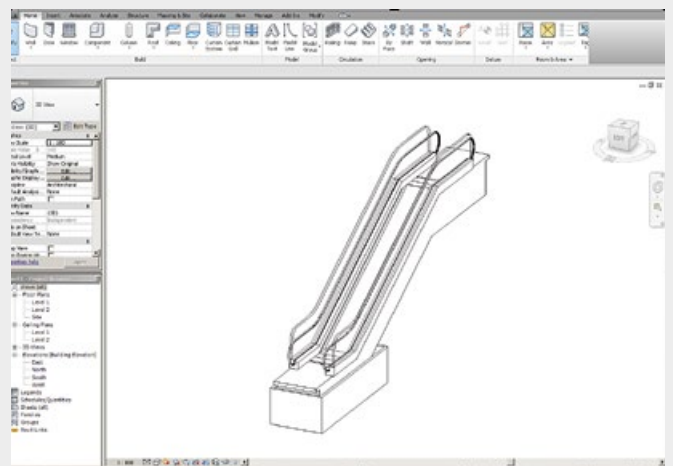

KONE provides innovative and eco-efficient solutions for elevators, escalators, automatic building doors and the systems that integrate them with today's intelligent buildings.

We support our customers every step of the way; from design, manufacturing and installation to maintenance and modernization. KONE is a global leader in helping our customers manage the smooth flow of people and goods throughout their buildings.

Our commitment to customers is present in all KONE solutions. This makes us a reliable partner throughout the life cycle of the building. We challenge the conventional wisdom of the industry. We are fast, flexible, and we have a well-deserved reputation as a technology leader, with such innovations as KONE MonoSpace®, KONE NanoSpace™ and KONE UltraRope®.

KONE employs close to 50,000 dedicated experts to serve you globally and locally.

KONE Corporation
www.kone.com